

CHALLENGER MOTOR AC-SERIES

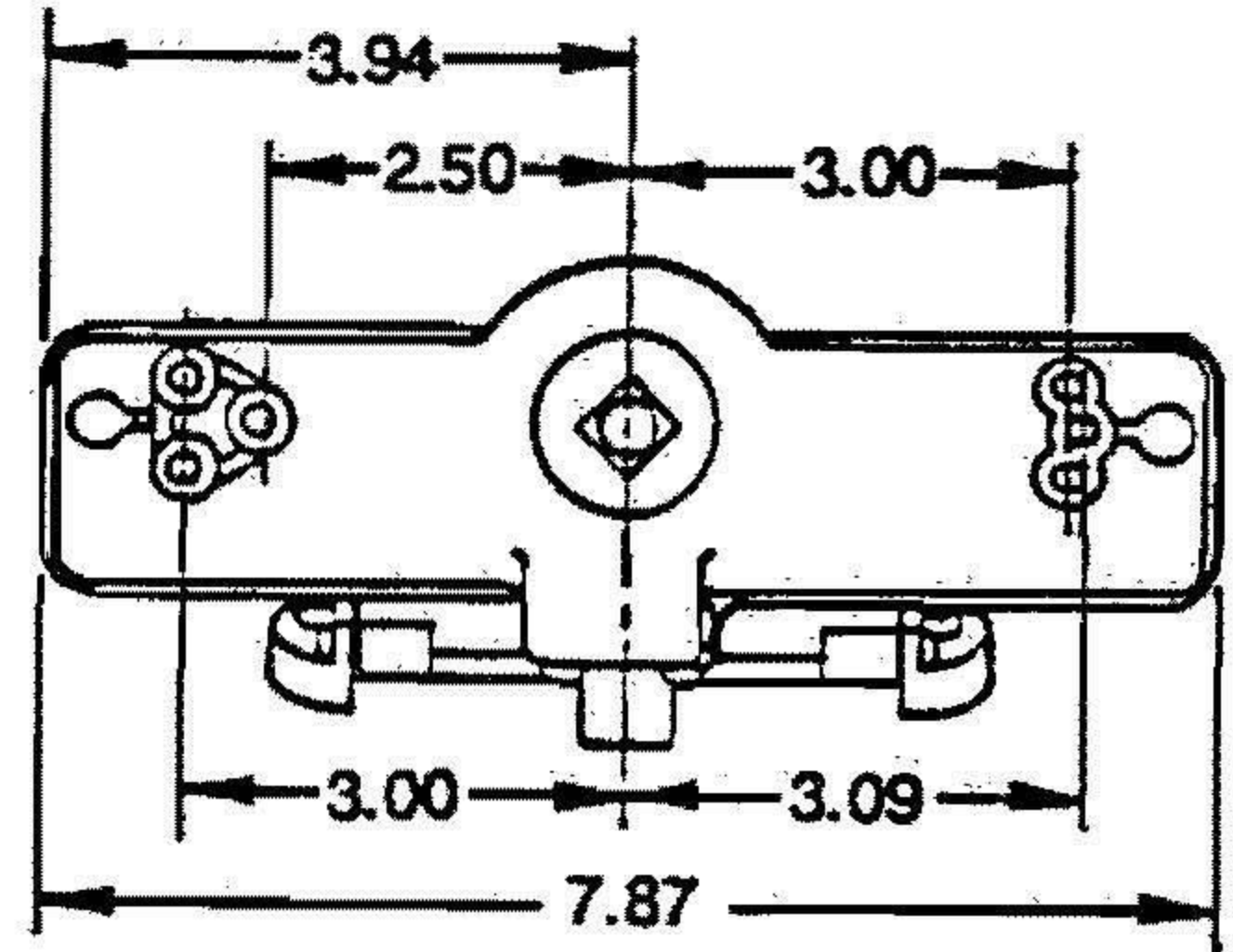
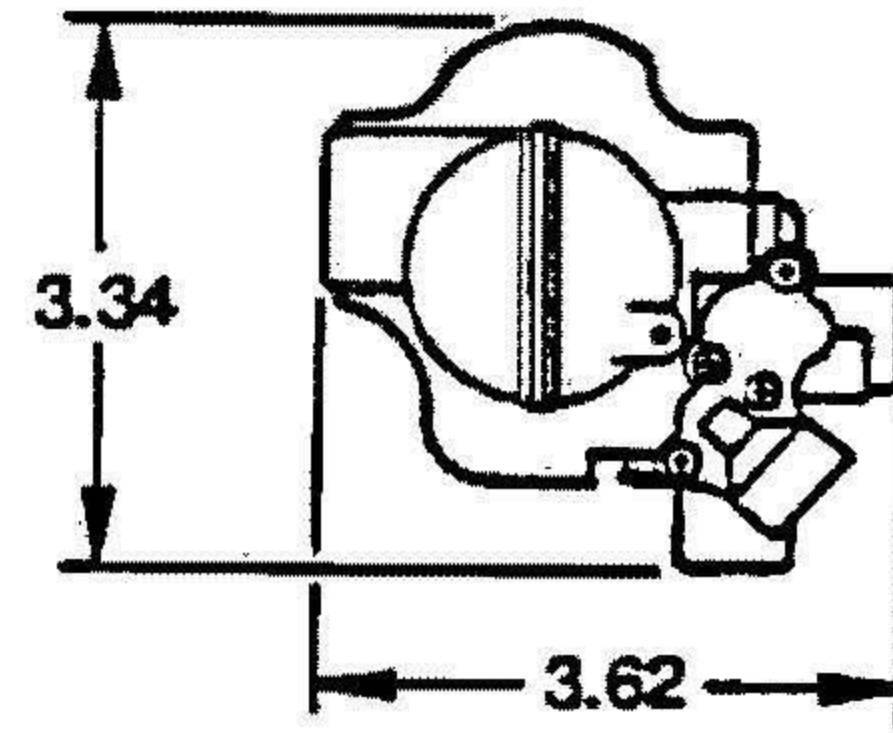
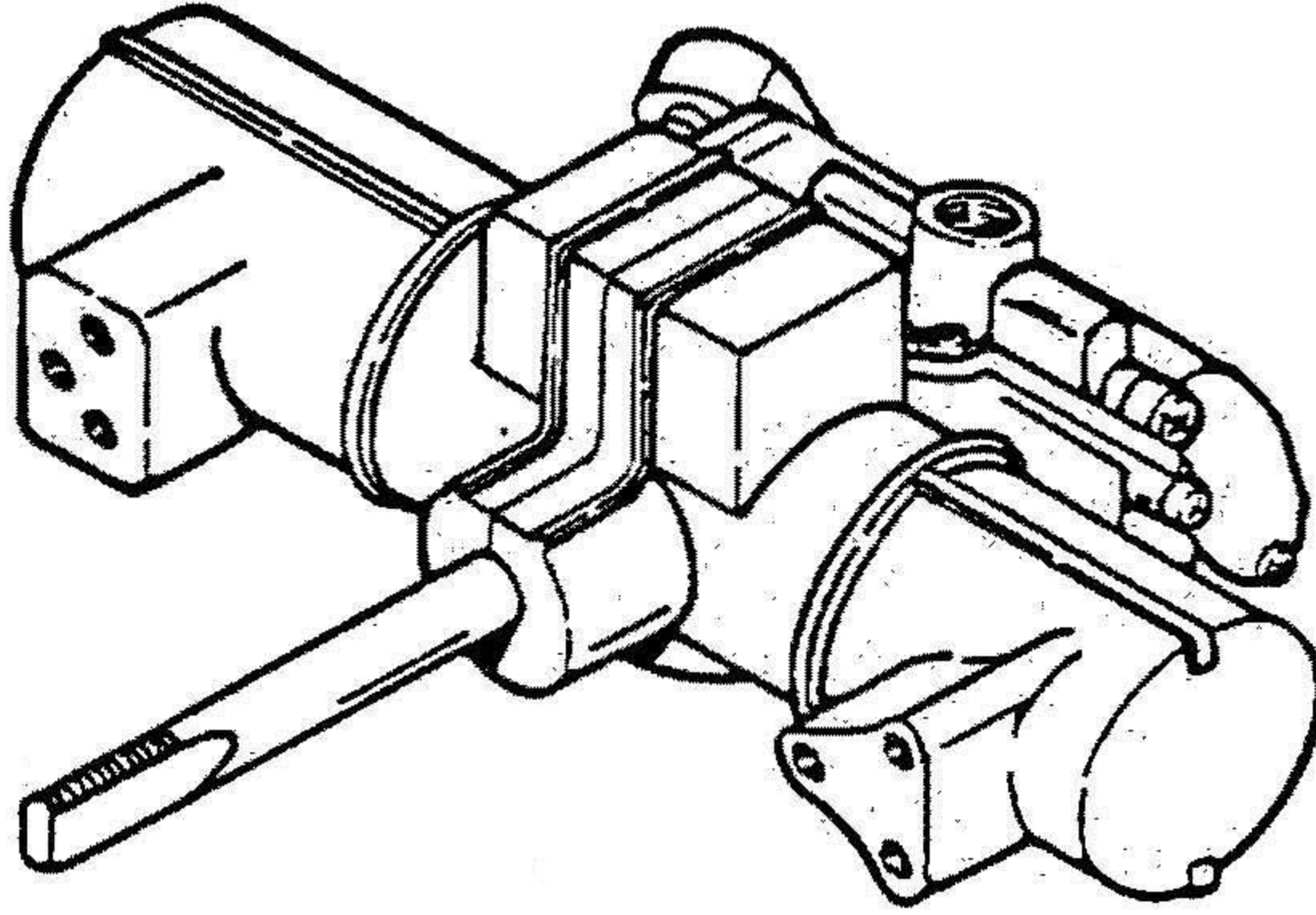

EXAMPLE - AC1/140080

SERIES NUMBER	OLD MOTOR NUMBER
AC-1	M-704-DEG
AC-2	M-714-DEG
AC-3	M-718-DEG
AC-4	MD-718-DEG
AC-5	M-540-DEG

AIR CONSUMPTION - 1.2 C.F.M. AT 100 P.S.I.

TORQUE - 9.5 FT. LBS. AT 100 P.S.I.

WEIGHT - 2.5 LBS. (APPROX.)

OPERATING PRESSURE - 30 TO 100 P.S.I.

SWEEP RANGE - 30 DEG. TO 140 DEG.